



**Health and Safety Warning:**

Ceramic fiber products are suspected of causing cancer by inhalation. All ceramic fiber products have a hazard communication warning label and a prop 65 warning for airborne fiber inhalation. You should minimize exposure to airborne fibers. When handling ceramic fiber we recommend using particulate respirator mask (N95), protective gloves, safety glasses and long sleeve clothing. For complete safety information consult the SDS sheet. <https://www.lynnmfg.com/documentation/>



**Before you start work:**

1. Read all instructions and check the kit number before starting work. **See Note A.**
2. Turn off service switch on boiler and all other electrical disconnect switches.
3. Close fuel supply valve(s) and disconnect fuel line from the burner.

**Removal:**

4. After completing the above safety steps, remove the oil burner from the Burner Mounting Plate.
5. Remove the Burner Mounting Plate by removing the nuts holding it in place.
6. Remove the Burner Mounting Plate Insulation.
7. Remove the Target Wall from the rear section of the boiler.
8. Inspect the rear section plug and remove if deteriorated.
9. Inspect the inside of the boiler, clean and remove any debris..

**Installation:**

11. If the Rear Section Plug is to be replaced, insert the new plug into the hole, tapered (small) side first and firmly press into place. Use a knife or hacksaw blade to shave the plug flush with the inside surface.
12. Install the new target wall as shown, up against the rear casting. No cements or fasteners are used to hold it in place. **See Note B.**
13. If replacing the Rope Seal, remove the paper backing from the adhesive on the rope and press the rope into the cleaned groove in the inside of the Burner Mounting Plate. **See Note D.**
14. Attach the Burner Mounting Plate Insulation to the inside of the Burner Mounting Plate using the hardware provided. The large stainless steel washers should be on the insulation side. The large Observation Port opening (4-1/2" high) and large burner opening should face the inside of the boiler.
15. Reinstall the Burner Mounting Plate. Tighten burner mounting plate evenly to slightly compress rope gasket. Overtightening will cause the plate to crack the corners.
16. Reconnect fuel and electric lines and turn on all valves and switches.
17. Fire the Burner. **See Note E.**

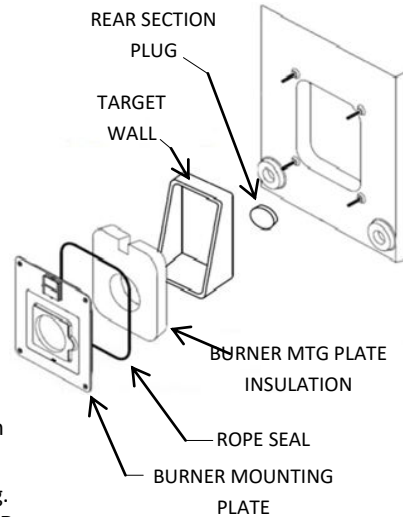

**Note A: Correct Kit**

Please check this is the correct kit for your make & model boiler by checking the box label or consulting our Ready Reference.

**Note B: Fitting Ceramic Fiber Pieces**

Many of the rigid ceramic fiber pieces are designed to be a firm press fit. To avoid breakage, press carefully and gradually. The fit may need to be adjusted by sanding or filing until a snug press fit is achieved.

**Note D: Installing Rope Door Seal**

After removing the old sealing rope from door perimeter, clean aggressively with a wire brush. Remove the paper backing from the rope adhesive, and press the rope into the sealing groove. Install so that the ends of the rope meet at the bottom of the door and butt firmly against each other. Maintain a gas-tight seal around door to avoid severe personal injury or death.

**Note E: Initial Firing**

Fire the burner for 15 minutes to allow ceramic fiber insulation to "cure". It is normal when first fired for some smoke and a slight odor to occur. Combustion test must be performed after curing process.

**Application, Installation and Use Warning:**

In applications including; boilers, furnaces, wood stoves, wood inserts, fireplaces, heating devices, and other appliances, parts must be used consistently with original equipment manufacturers specifications, design, function and operation.

Improper installation or use of this product could result in a fire, smoke inhalation or carbon monoxide poisoning. Products should be installed by a licensed and certified technician in compliance with all national, state and local codes. Products should be inspected annually by a licensed and certified technician for wear, brittleness, cracking or crumbling, and replaced as necessary. Lynn Manufacturing, Inc. recommends installers certified by NFI, CSIA or NORA.

Never work on a piece of equipment or touch the fibrous product when it is hot, as the product may show no visible signs of heat from glowing or smoking.

Lynn Manufacturing, Inc offers hundreds of products with many applications. Determining whether the product is a fit for the particular purpose and suitable for an application is the sole responsibility of the purchaser/installer.

In no event shall Lynn Manufacturing, Inc be liable for any damages to property or life arising from or connected with the use of this product.

V0420